

SCHEMA MONTAGGIO NEW CAMP

1. Fissare le gambe : 16 bulloni / 16 dadi / 16 rondelle / 8 piastre plastica)

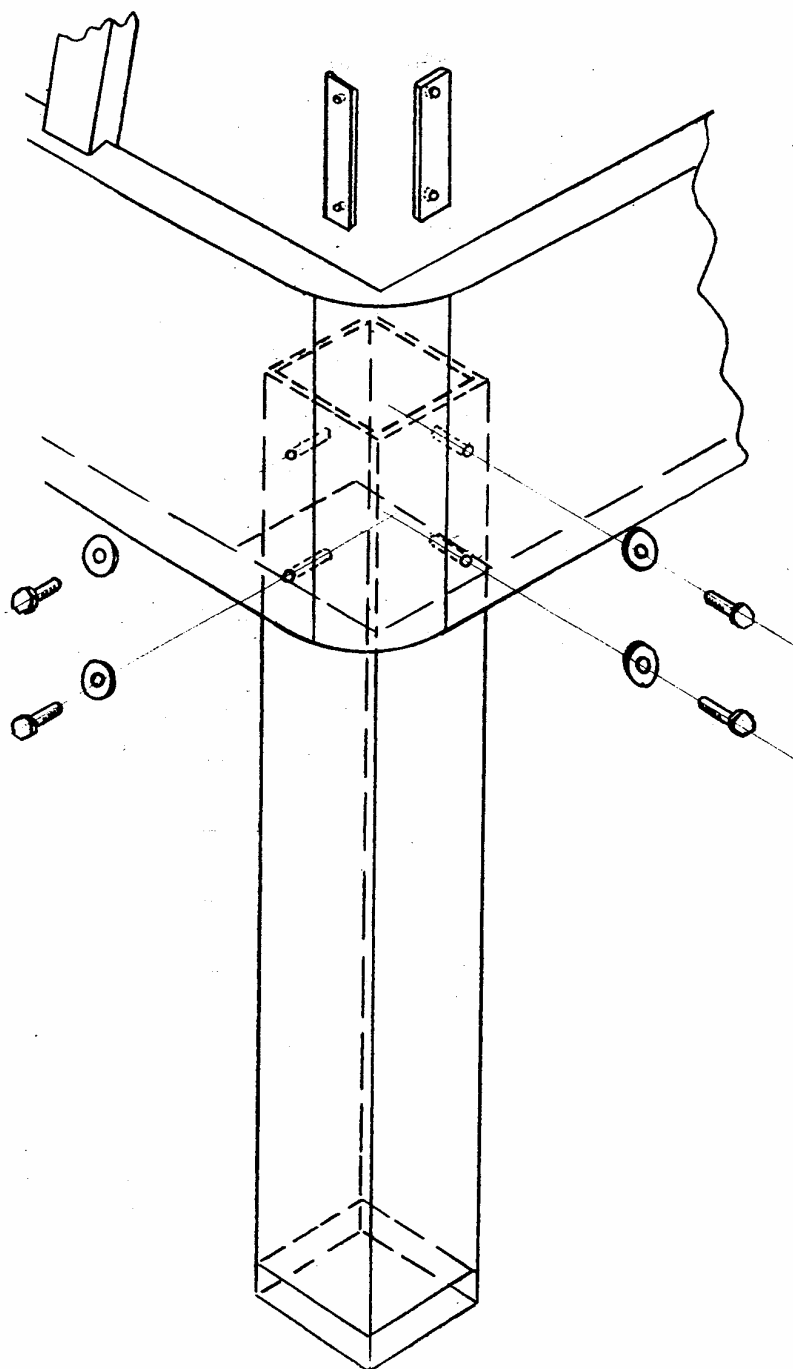

2. Assemblare le aste:

